

Principle of Inertization / Blanketing

Standard Pressure Service

Back pressure relief valve
Type LPS or ZM-B

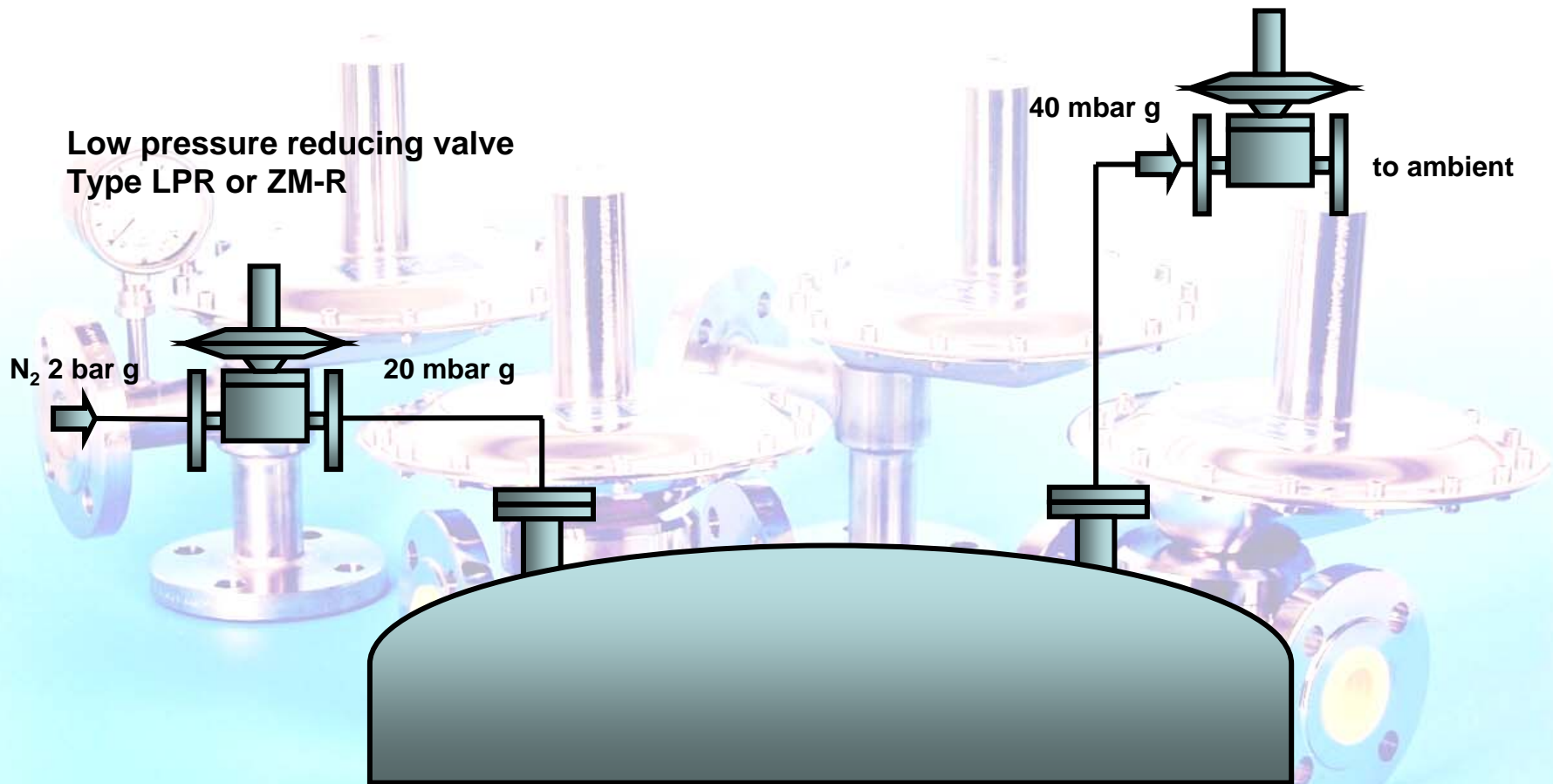

Principle of Inertization / Blanketing

Modern inertization

The technology of ZIMMERLI Messtechnik AG can save you a lot of money and energy. This is how it works: From the supply network, nitrogen with a pressure of up to 10 bar g is fed directly into the Zimmerli low pressure regulator (ZM-R or LPR) where its pressure is reduced down to e.g. +20 mbar g.

On the exit side of the process, a pressure relief valve (ZM-B or LPS) does not release protective gas until the pressure has risen to e.g. 40 mbar g. As long as the process pressure ranges between 20 and 40 mbar g, absolutely no nitrogen is consumed.

Process Filling:

When material is filled into the process, the protective gas is compressed accordingly. This raises the reactor pressure. As soon as its limit (e.g. 40 mbar g) has been reached, the Zimmerli pressure relief valve opens thus preventing any further pressure increase. Zimmerli pressure relief valves are also called back pressure relief valves.

Process Discharge:

When material is taken from process, the protective gas atmosphere expands accordingly. This decreases the reactor pressure. As soon as the pressure falls below the limit (e.g. 20 mbar g) the Zimmerli reducing valve opens to prevent any further loss of pressure. Hence the blanketing pressure always ranges between the limit of the reducer (20 mbar g) and that of the pressure relief valve (40 mbar g).

Technology:

Zimmerli low pressure reducing valves and Zimmerli low pressure relief valves are sensitive differential pressure regulators, which always maintain their set limits on the basis of the momentary atmospheric pressure. This safeguards constant blanketing pressure under any atmospheric conditions.

Optionally, all low pressure regulators can be equipped ex works with active OFF or active ON safety features.

Principle of Dome-loaded Regulation

Variable Pressure Service

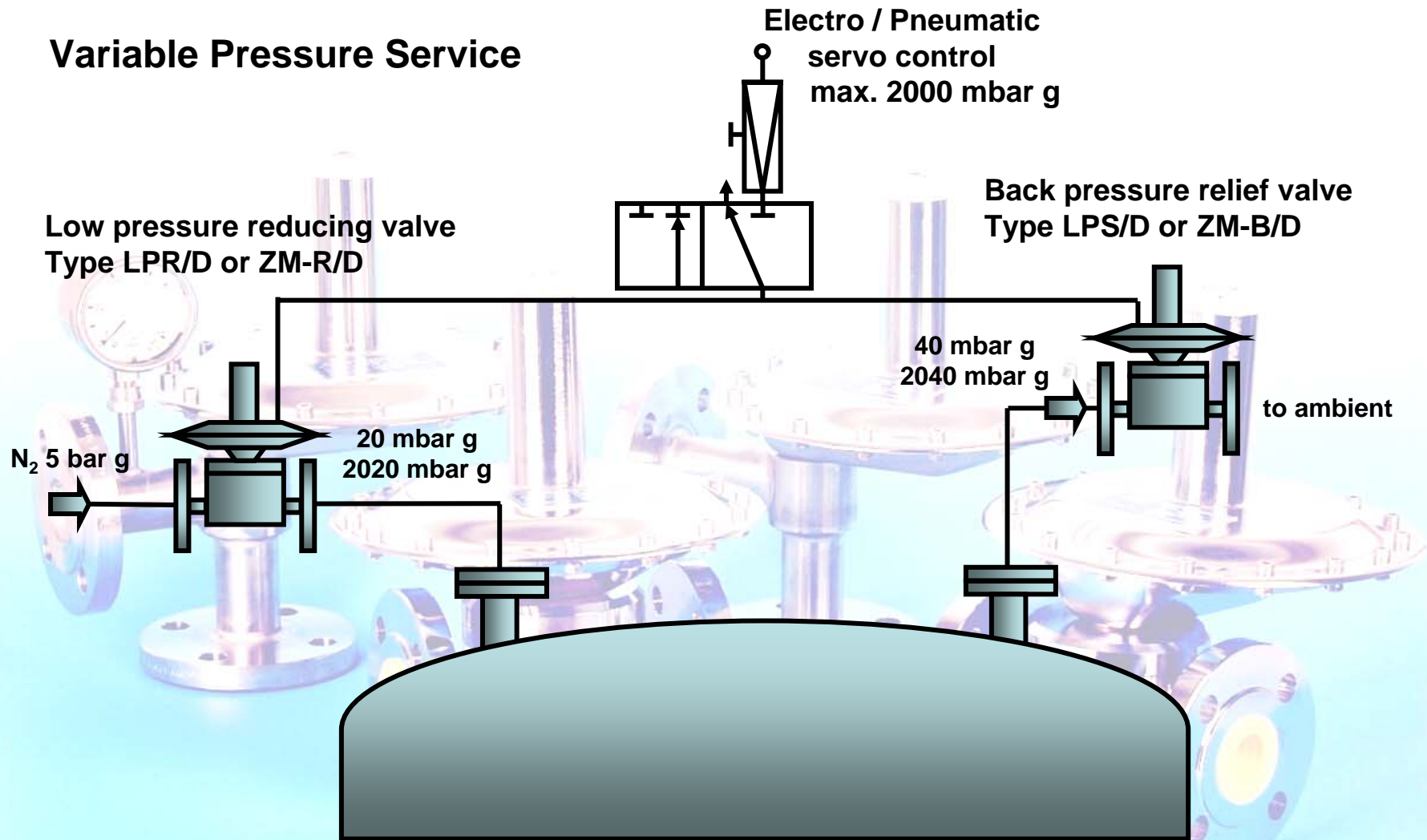

Principle of Dome-loaded Regulation

High pressure blanketing:

This application describes the operation of a plant using dome-loaded pressure regulation. From the supply network, nitrogen with a pressure of up to 10 bar g is fed directly into the Zimmerli dome-loaded pressure regulator (ZM-R/D or LPR/D) where its pressure is reduced to e.g. +20 mbar g.

On the exit side of the process, a dome-loaded pressure relief valve (ZM-B/D or LPS/D) does not release protective gas until the pressure has risen to e.g. 40 mbar g. As long as process pressure ranges between 20 and 40 mbar g, absolutely no nitrogen is consumed.

Process Filling:

When material is filled into the process, the protective gas is compressed accordingly. This raises the reactor pressure. As soon as its limit (e.g. 40 mbar g) has been reached, the Zimmerli pressure relief valve opens thus preventing any further pressure increase. Zimmerli pressure relief valves are also called back pressure relief valves.

Process Discharge:

When material is taken from reactor, the protective gas atmosphere expands accordingly. This decreases the reactor pressure. As soon as the pressure falls below the limit (e.g. 20 mbar g) the Zimmerli reducing valve opens to prevent any further loss of pressure. Hence the blanketing pressure always ranges between the limit of the reducer (20 mbar g) and that of the pressure relief valve (40 mbar g).

Dome-loaded pressure regulation using a pilot controller:

A pilot controller actuates Zimmerli low pressure regulators and Zimmerli pressure relief valves simultaneously with a dome-loaded pressure of up to 2000 mbar g for high pressure blanketing. This shifts the limit values proportionally up to e.g. 2020 and 2040 mbar g. Various types of suitable pilot controllers are available on request. High pressure blanketing allows, for example, faster inertization or product conveyance without a pump.

Optionally, all low pressure regulators can be equipped ex works with active OFF or active ON safety features.

Principle of Negative Pressure Regulation

Permanent Vacuum Service

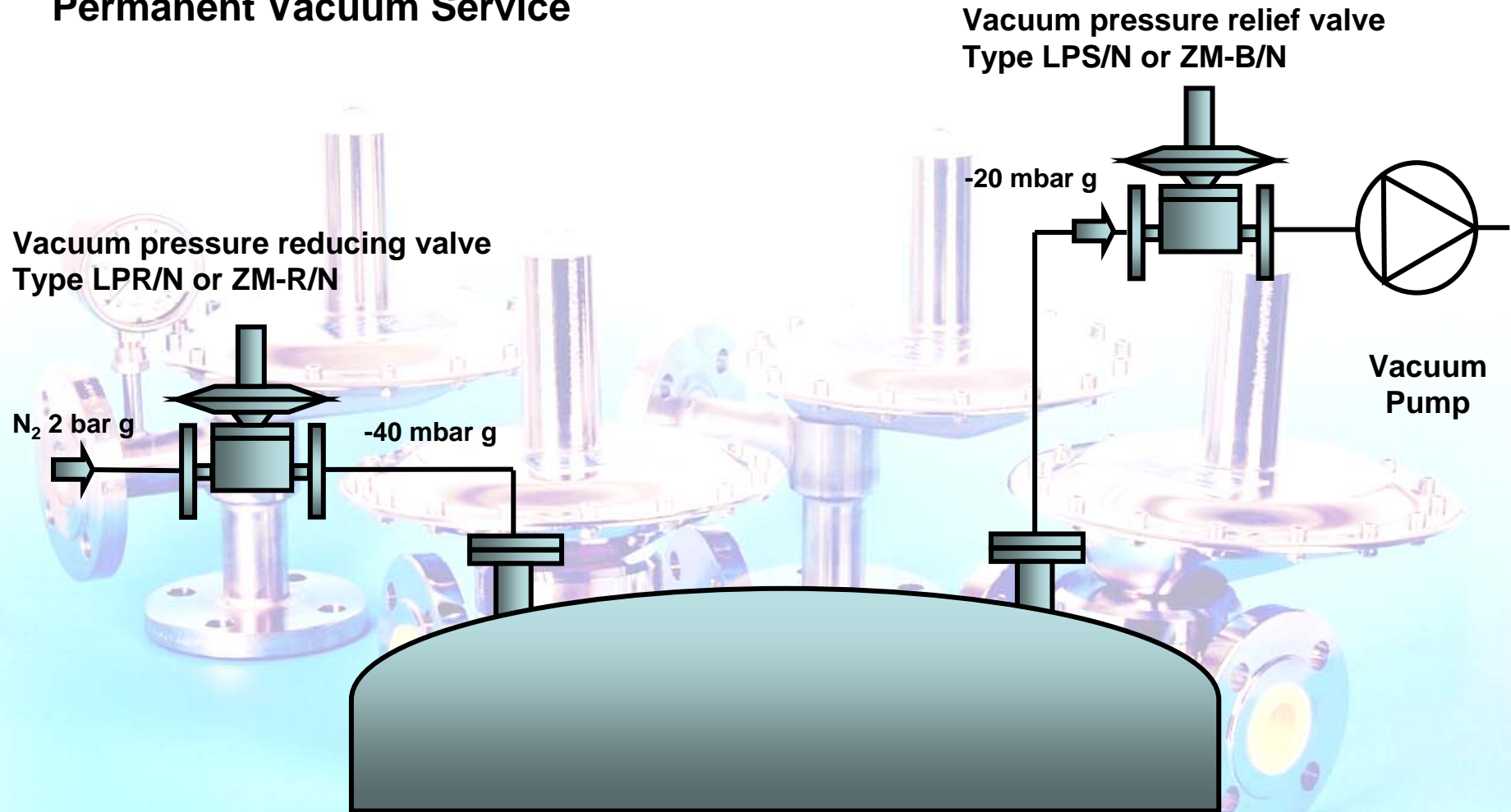

Principle of Negative Pressure Regulation

Negative pressure blanketing:

This application describes the operation of a plant using negative pressure regulation. From the supply network, nitrogen with a pressure of up to 10 bar g is fed directly into the Zimmerli negative pressure regulator (ZM-R/N or LPR/N) where its pressure is reduced to e.g. -40 mbar g.

On the exit side of the process, a Zimmerli negative pressure relief valve (ZM-B/N or LPS/N) does not release protective gas until the pressure has risen to e.g. -20 mbar g. As long as the process pressure ranges between -40 and -20 mbar g, absolutely no nitrogen is consumed.

Process Filling:

When material is filled into the process, the protective gas is compressed accordingly. This raises the reactor pressure. As soon as its limit (e.g. -20 mbar g) has been reached, the Zimmerli pressure relief valve opens thus preventing any further pressure increase. Zimmerli pressure relief valves are also called back pressure relief valves.

Process Discharge:

When material is taken from reactor, the protective gas atmosphere expands accordingly. This decreases the reactor pressure. As soon as the pressure falls below the limit (e.g. -40 mbar g) the Zimmerli reducing valve opens to prevent any further loss of pressure. Hence the blanketing pressure always ranges between the limit of the reducer (-40 mbar g) and that of the pressure relief valve (-20 mbar g).

Important note:

Negative pressure blanketing only works if, for example, a vacuum pump provides the necessary negative pressure behind the pressure relief valve. In the case outlined above, this negative pressure has to be below -20 mbar g in any case, so that the pressure relief valve can discharge at all.

Zimmerli negative pressure regulators and Zimmerli negative pressure relief valves are vacuum tight.

Optionally, all low pressure regulators can be equipped ex works with active OFF or active ON safety features.

Application Hints

Short distance*:

Install regulators as close to tank or process as ever possible. Dynamic pressure drop in longer pipes may limit gas flow dramatically.

Flow direction:

Care on correct flow direction as per flow tag on each regulator. Wrong flow direction causes malfunction (no flow or no pressure control).

Recommended:
vertical installation
Top/bottom flow

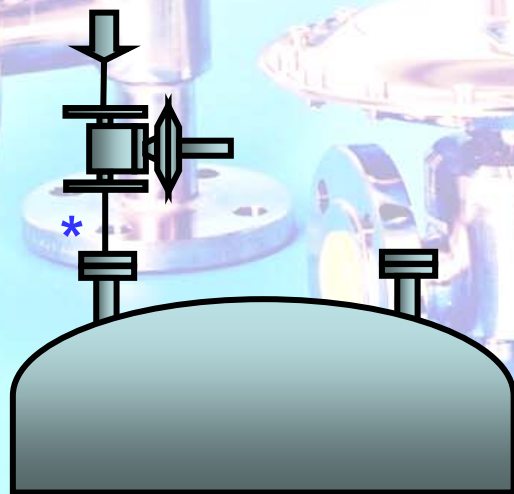

Recommended:
horizontal installation

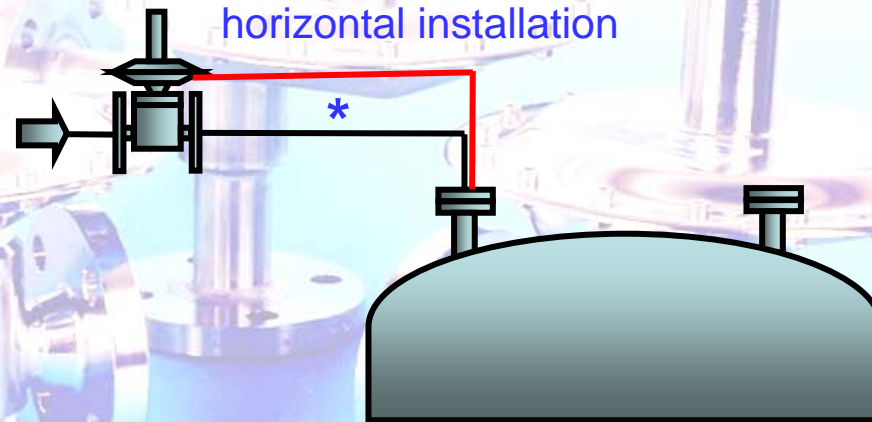

*In case of longer distance between regulator and process a “C-connection” with pulse line is required at all.

Application Hints

Flow direction:

Horizontal flow direction is ideal.

Top/bottom flow direction is acceptable

Do not:

Do never ever install device upside/down!

Prevent bottom/top flow direction (danger of condensate in diaphragm housing)

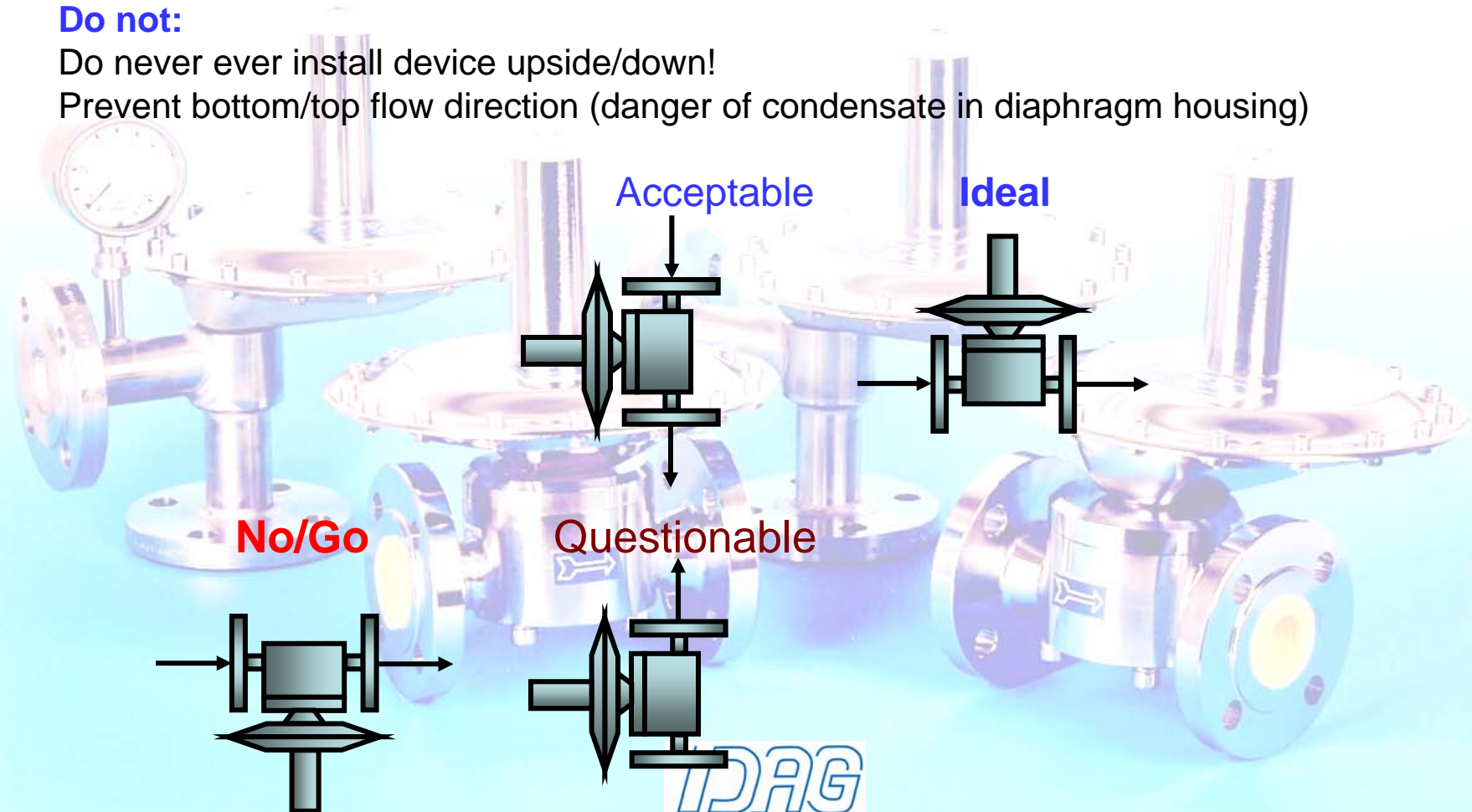

Application Hints

Care on Boyle Mariott Gas Low $p_1 \times V_1 = p_2 \times V_2$

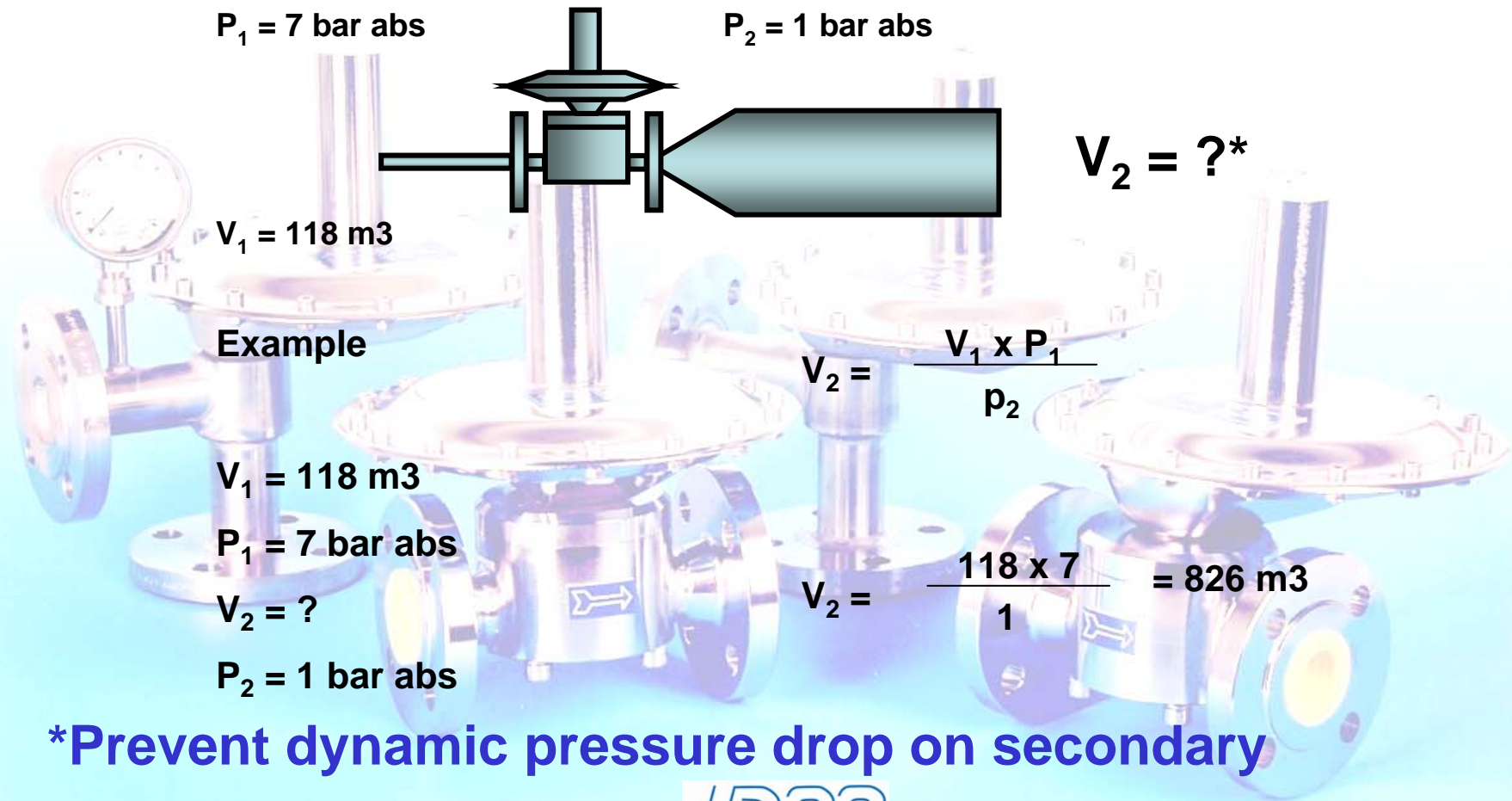

***Prevent dynamic pressure drop on secondary**



Application Hints

This installation creates malfunction due to pulsation and chatter effects!
Flowmeter pressure drop is too high!

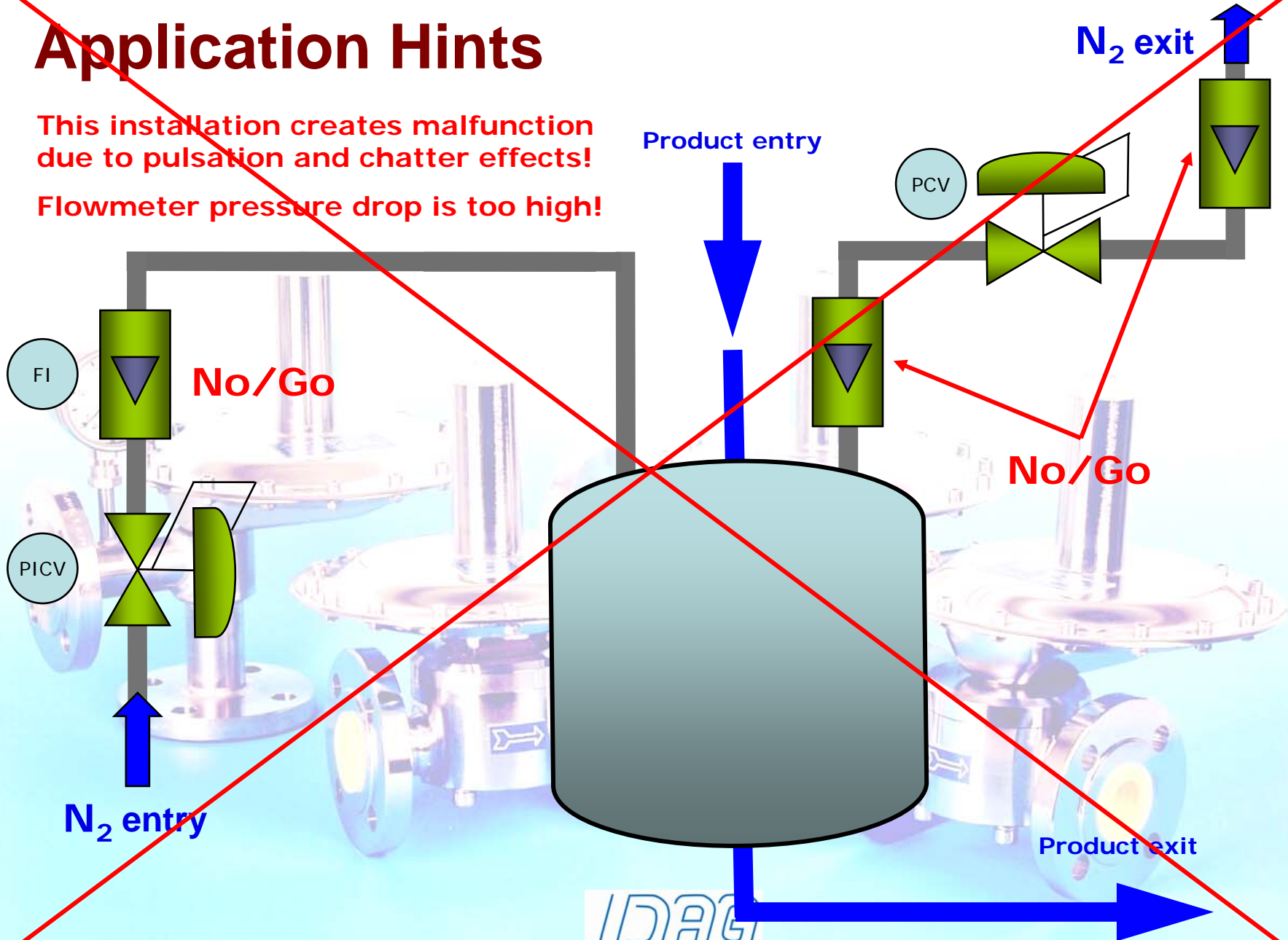

Application Hints

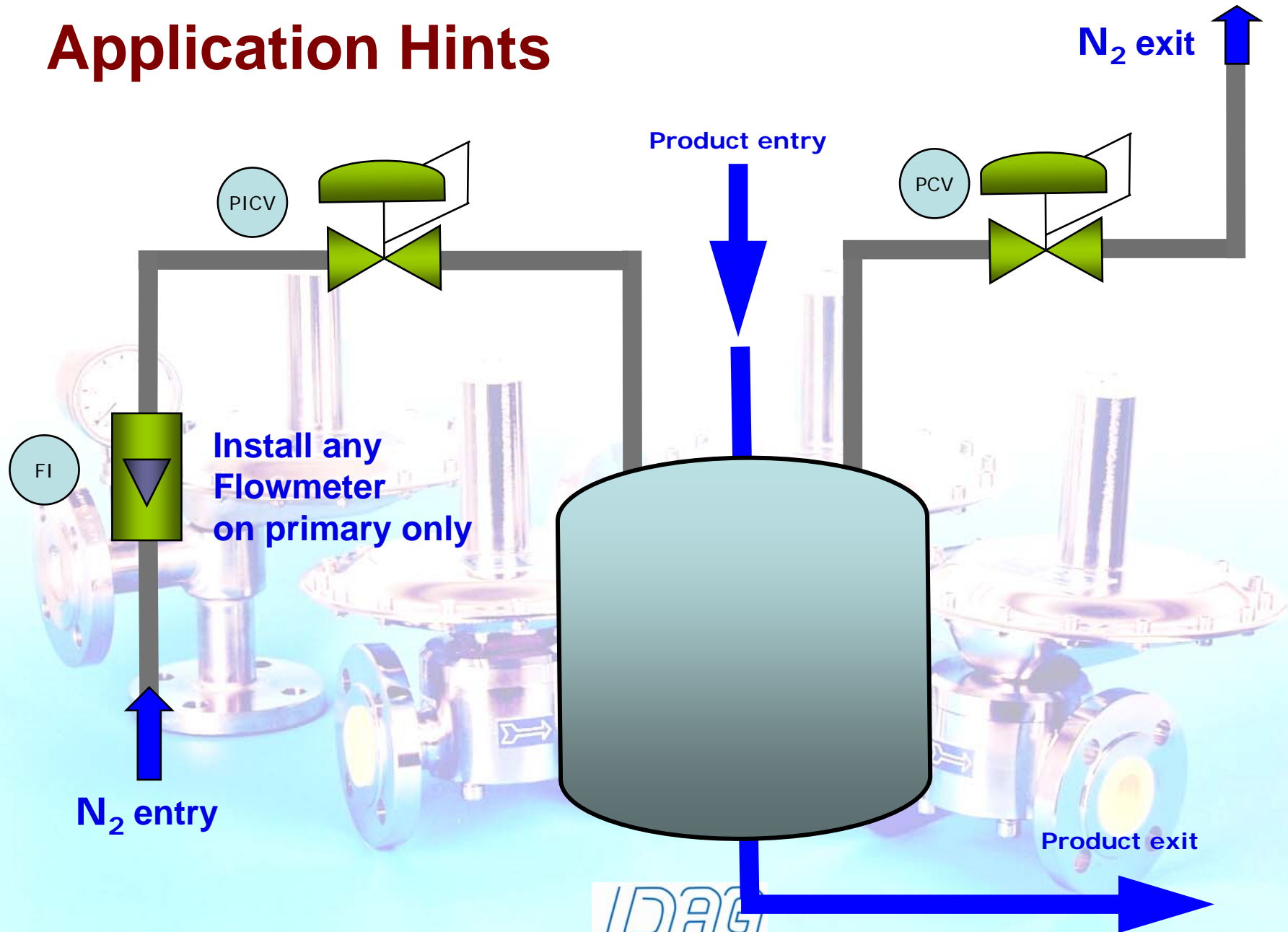

Install any
Flowmeter
on primary only

Application Hints

Application: out-door

Protect this area against moisture penetration with a type of cover

Also: as per model option

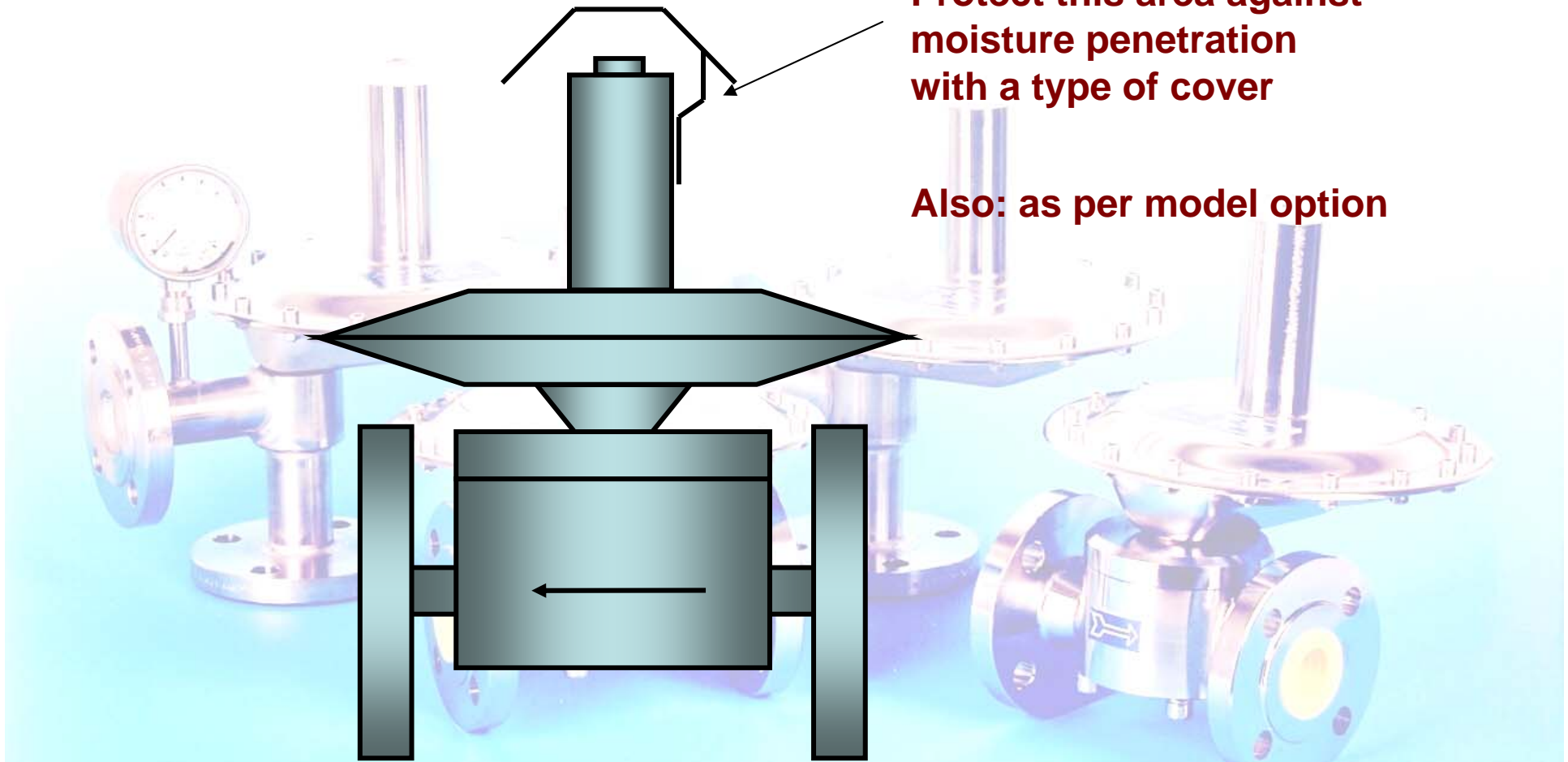

Application Hints

Bench Calibration:

**Calibrate set-point as per
real installation position
(vertical or horizontal)**

**Prevent pressure shock
during calibration
(open valve carefully)**

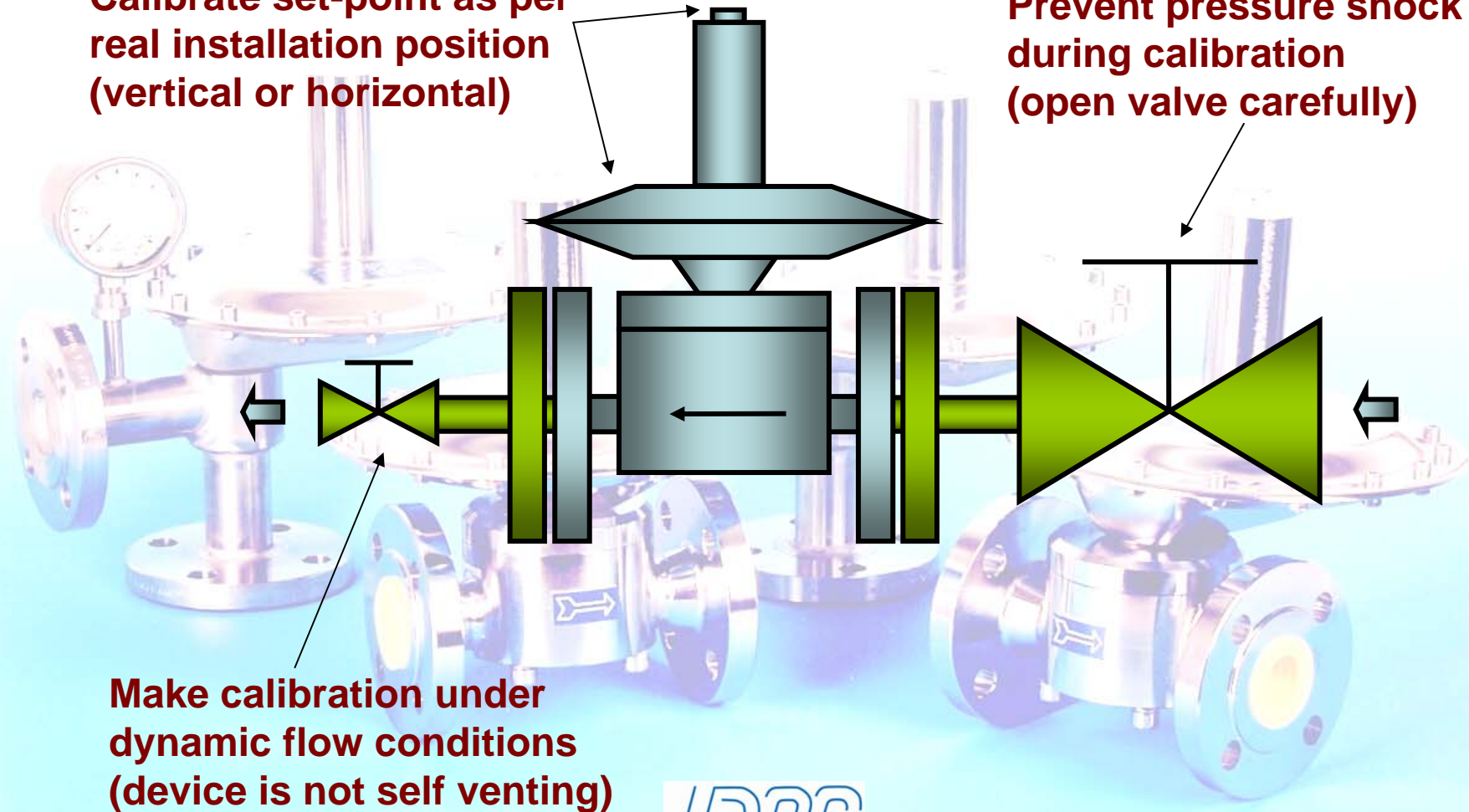

**Make calibration under
dynamic flow conditions
(device is not self venting)**

IDAG
DRUCKREGLER

Application Hints

1. Select **reducer valve seat** at least as per max product **discharge rate** of tank or vessel (worst case flow rate) x 2*
2. Select **relief valves seat** at least as per max product **filling rate** of tank or vessel (worst case flow rate) x 2*
3. * Alternatively, use **Flow Computation** program (as per download)
4. Reducing- and Relief-valves need to be installed as **close to process** as ever possible (prevent long pipe sections and any **flow restrictions**)
5. Prefer **horizontal** installation (vertical installation on request)
6. Care on **flow direction** as per flow mark
7. In case of collectors or longer pipe sections used between reducer and process, use generally option "**C-connection**" (with pulse line to process)
8. Prevent **pressure shock** on primary side (open ball valve slowly)
9. In case of questions left, email **questionnaire** – we help you!

If you care on this, you will be happy with Zimmerli valves, long term!